

Chapter 3

Arithmetic for Computers

Arithmetic for Computers

- Operations on integers
 - Addition and subtraction
 - Multiplication and division
 - Dealing with overflow
- Floating-point real numbers
 - Representation and operations

Integer Addition

■ Example: $7 + 6$

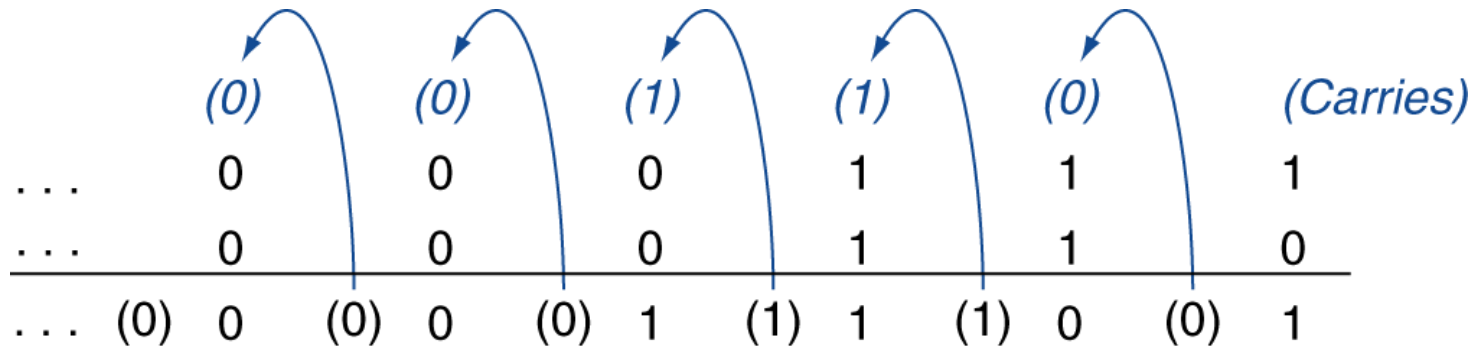

■ Overflow if result out of range

- Adding +ve and -ve operands, no overflow
- Adding two +ve operands
 - Overflow if result sign is 1
- Adding two -ve operands
 - Overflow if result sign is 0

Integer Subtraction

- Add negation of second operand
- Example: $7 - 6 = 7 + (-6)$

+7:	0000 0000 ... 0000 0111
-6:	1111 1111 ... 1111 1010
<hr/>	
+1:	0000 0000 ... 0000 0001

- Overflow if result out of range
 - Subtracting two +ve or two -ve operands, no overflow
 - Subtracting +ve from -ve operand
 - Overflow if result sign is 0
 - Subtracting -ve from +ve operand
 - Overflow if result sign is 1

Arithmetic for Multimedia

- Graphics and media processing operates on vectors of 8-bit and 16-bit data
 - Use 64-bit adder, with partitioned carry chain
 - Operate on 8×8-bit, 4×16-bit, or 2×32-bit vectors
 - SIMD (single-instruction, multiple-data)
- Saturating operations
 - On overflow, result is largest representable value
 - c.f. 2s-complement modulo arithmetic
 - E.g., clipping in audio, saturation in video

Multiplication

- Start with long-multiplication approach

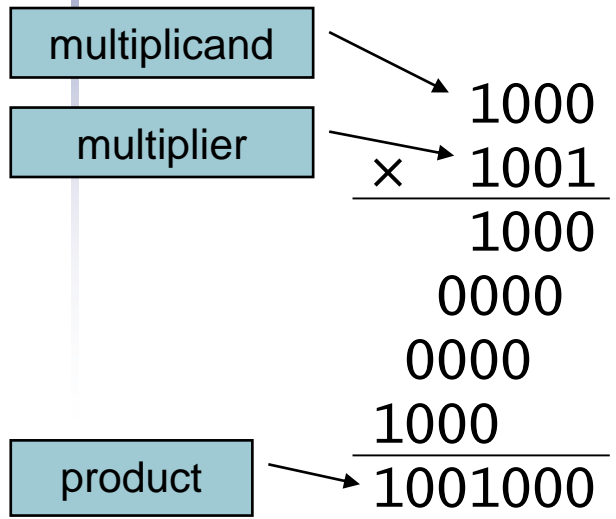

Length of product is the sum of operand lengths

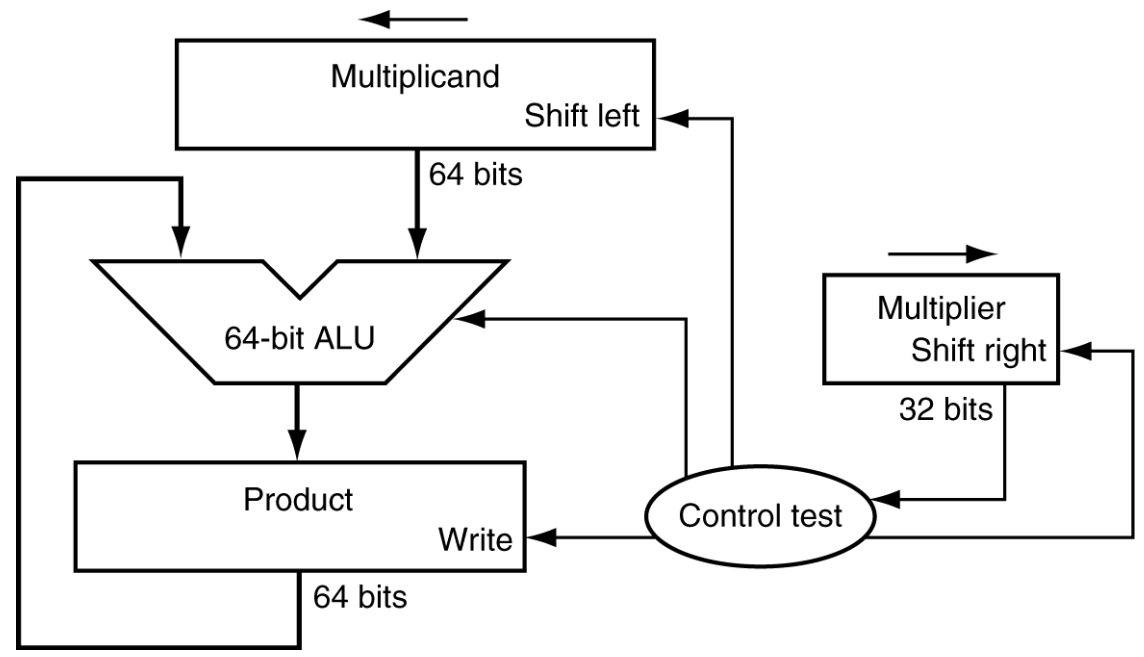

Multiplication Hardware

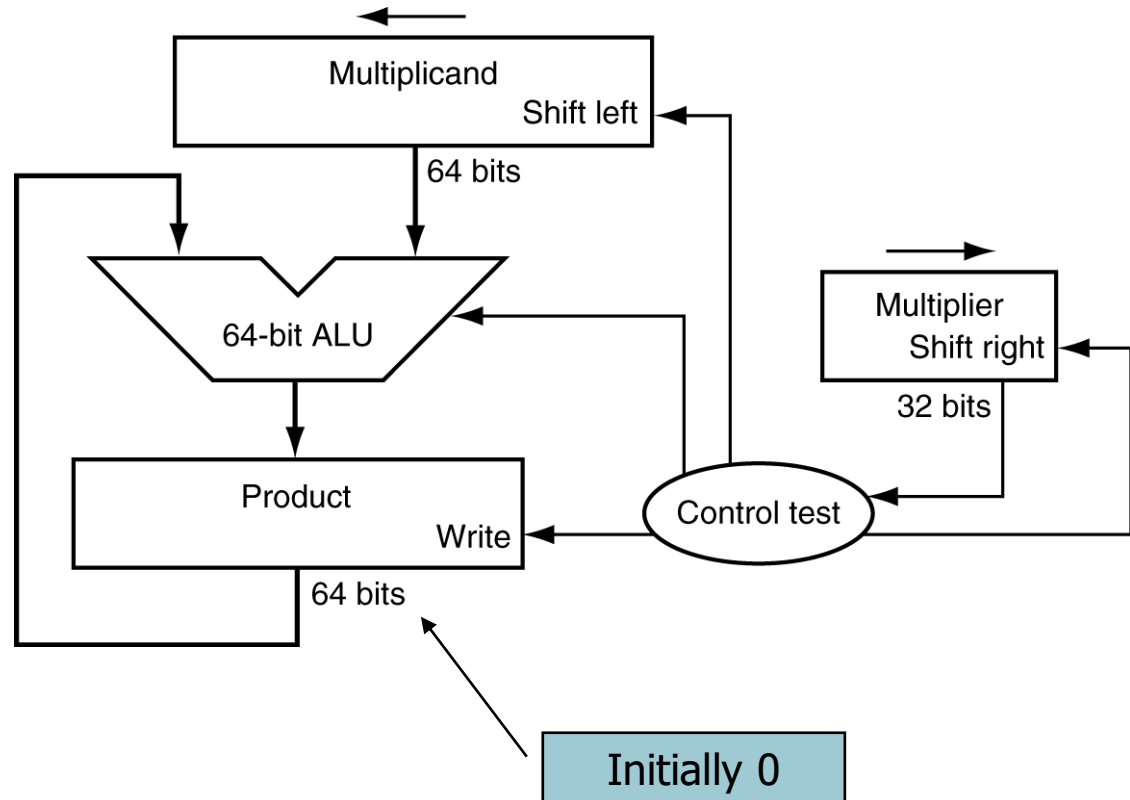
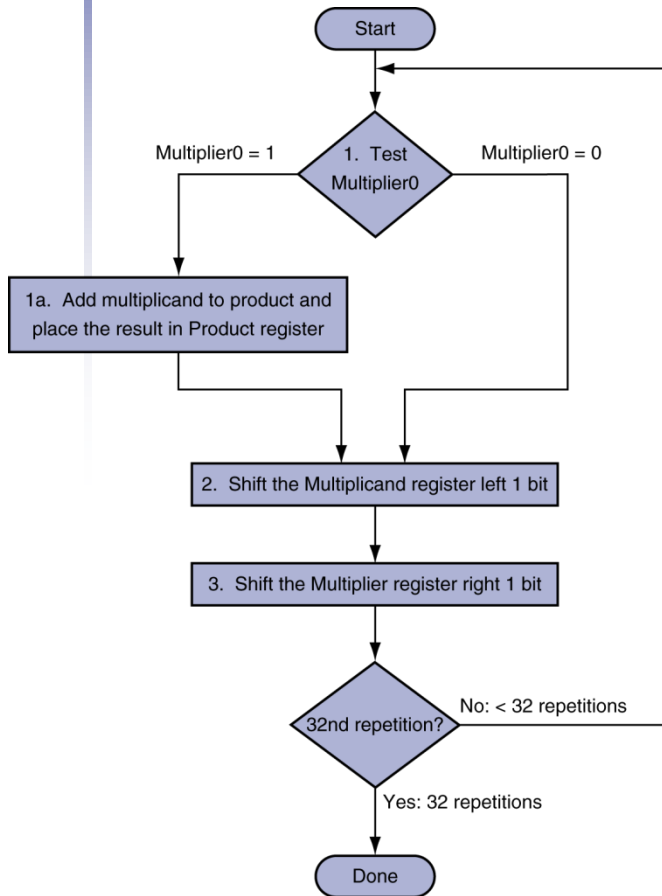

Optimized Multiplier

- Perform steps in parallel: add/shift

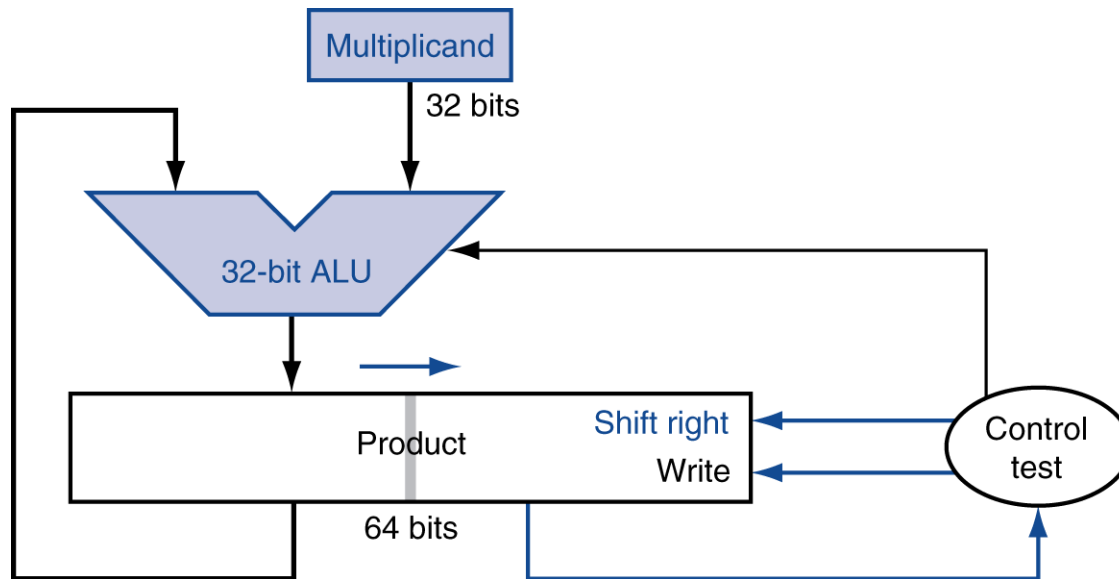

- One cycle per partial-product addition
 - That's ok, if frequency of multiplications is low

Faster Multiplier

- Uses multiple adders
 - Cost/performance tradeoff

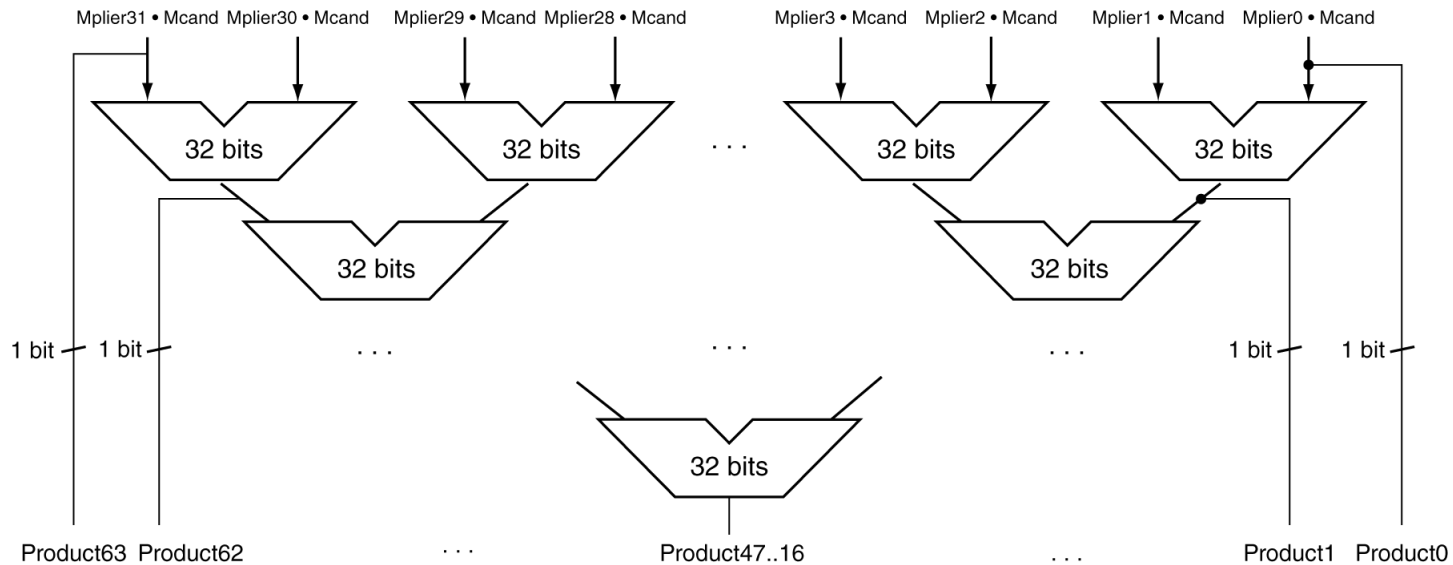

- Can be pipelined
 - Several multiplication performed in parallel

LEGv8 Multiplication

- Three multiply instructions:
 - MUL: multiply
 - Gives the lower 64 bits of the product
 - SMULH: signed multiply high
 - Gives the upper 64 bits of the product, assuming the operands are signed
 - UMULH: unsigned multiply high
 - Gives the lower 64 bits of the product, assuming the operands are unsigned

Division

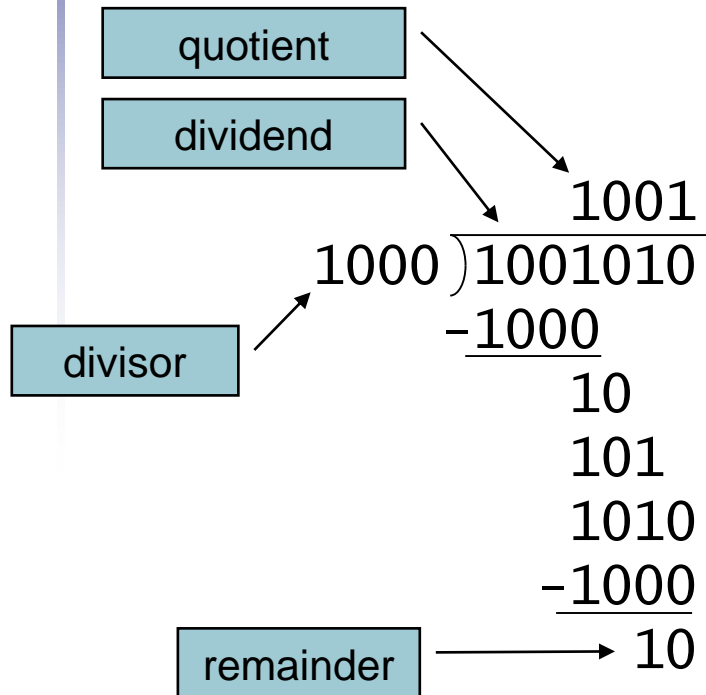

n-bit operands yield *n*-bit quotient and remainder

- Check for 0 divisor
- Long division approach
 - If divisor \leq dividend bits
 - 1 bit in quotient, subtract
 - Otherwise
 - 0 bit in quotient, bring down next dividend bit
- Restoring division
 - Do the subtract, and if remainder goes < 0 , add divisor back
- Signed division
 - Divide using absolute values
 - Adjust sign of quotient and remainder as required

Division Hardware

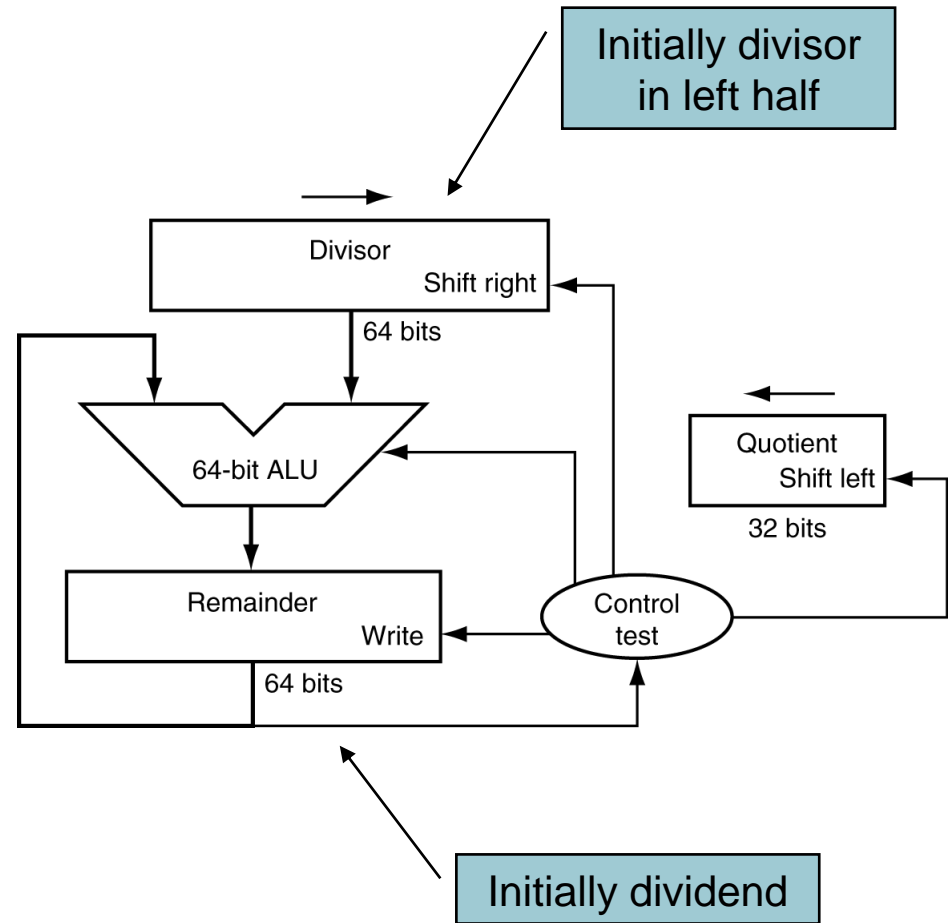
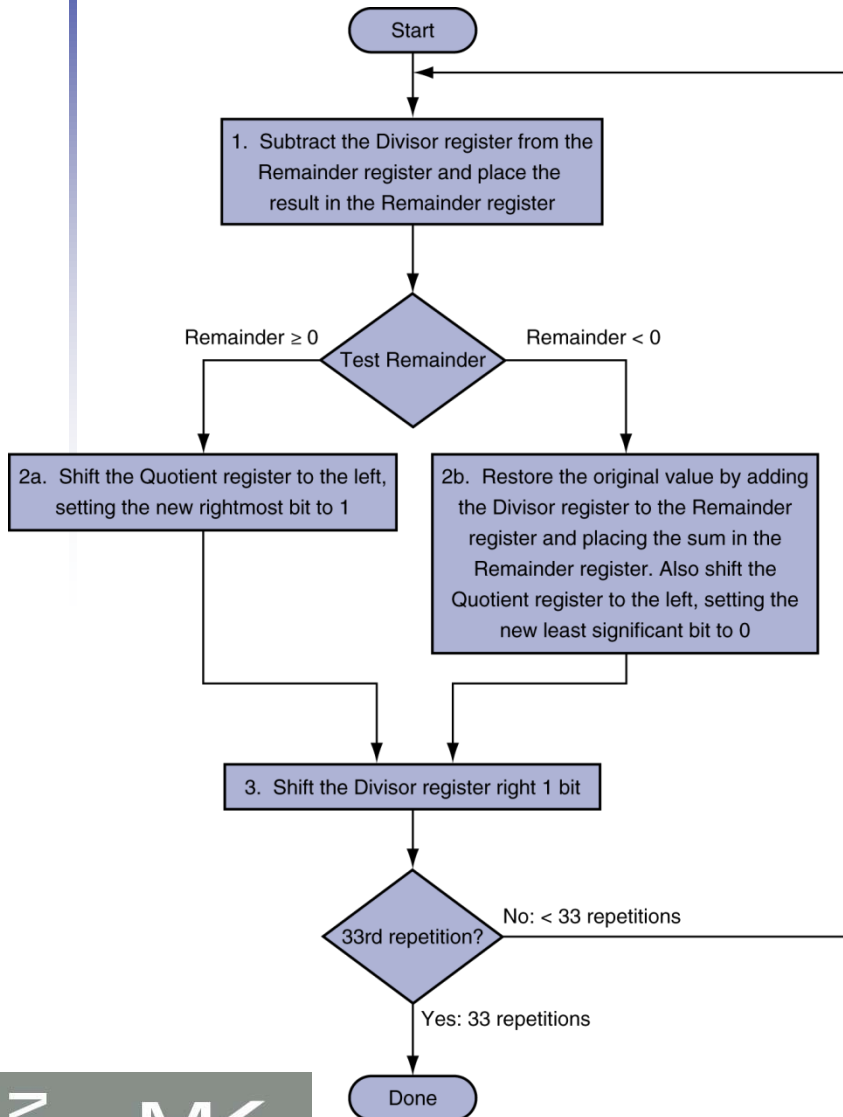

Optimized Divider

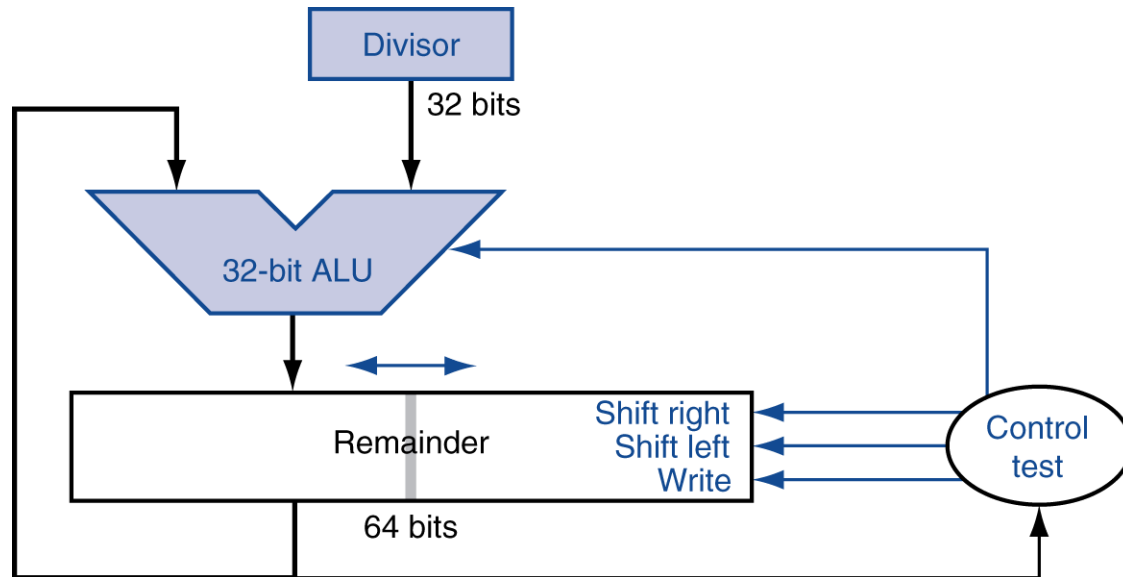

- One cycle per partial-remainder subtraction
- Looks a lot like a multiplier!
 - Same hardware can be used for both

Faster Division

- Can't use parallel hardware as in multiplier
 - Subtraction is conditional on sign of remainder
- Faster dividers (e.g. SRT division) generate multiple quotient bits per step
 - Still require multiple steps

LEGv8 Division

- Two instructions:
 - SDIV (signed)
 - UDIV (unsigned)
- Both instructions ignore overflow and division-by-zero

Floating Point

- Representation for non-integral numbers
 - Including very small and very large numbers
- Like scientific notation
 - -2.34×10^{56} ← normalized
 - $+0.002 \times 10^{-4}$ ← not normalized
 - $+987.02 \times 10^9$ ← not normalized
- In binary
 - $\pm 1.xxxxxxx_2 \times 2^{yyyy}$
- Types `float` and `double` in C

Floating Point Standard

- Defined by IEEE Std 754-1985
- Developed in response to divergence of representations
 - Portability issues for scientific code
- Now almost universally adopted
- Two representations
 - Single precision (32-bit)
 - Double precision (64-bit)

IEEE Floating-Point Format

single: 8 bits
double: 11 bits

single: 23 bits
double: 52 bits



$$x = (-1)^S \times (1 + \text{Fraction}) \times 2^{(\text{Exponent} - \text{Bias})}$$

- S: sign bit (0 \Rightarrow non-negative, 1 \Rightarrow negative)
- Normalize significand: $1.0 \leq |\text{significand}| < 2.0$
 - Always has a leading pre-binary-point 1 bit, so no need to represent it explicitly (hidden bit)
 - Significand is Fraction with the “1.” restored
- Exponent: excess representation: actual exponent + Bias
 - Ensures exponent is unsigned
 - Single: Bias = 127; Double: Bias = 1203

Single-Precision Range

- Exponents 00000000 and 11111111 reserved
- Smallest value
 - Exponent: 00000001
⇒ actual exponent = $1 - 127 = -126$
 - Fraction: 000...00 ⇒ significand = 1.0
 - $\pm 1.0 \times 2^{-126} \approx \pm 1.2 \times 10^{-38}$
- Largest value
 - exponent: 11111110
⇒ actual exponent = $254 - 127 = +127$
 - Fraction: 111...11 ⇒ significand ≈ 2.0
 - $\pm 2.0 \times 2^{+127} \approx \pm 3.4 \times 10^{+38}$

Double-Precision Range

- Exponents 0000...00 and 1111...11 reserved
- Smallest value
 - Exponent: 00000000001
⇒ actual exponent = $1 - 1023 = -1022$
 - Fraction: 000...00 ⇒ significand = 1.0
 - $\pm 1.0 \times 2^{-1022} \approx \pm 2.2 \times 10^{-308}$
- Largest value
 - Exponent: 11111111110
⇒ actual exponent = $2046 - 1023 = +1023$
 - Fraction: 111...11 ⇒ significand ≈ 2.0
 - $\pm 2.0 \times 2^{+1023} \approx \pm 1.8 \times 10^{+308}$

Floating-Point Precision

- Relative precision
 - all fraction bits are significant
 - Single: approx 2^{-23}
 - Equivalent to $23 \times \log_{10} 2 \approx 23 \times 0.3 \approx 6$ decimal digits of precision
 - Double: approx 2^{-52}
 - Equivalent to $52 \times \log_{10} 2 \approx 52 \times 0.3 \approx 16$ decimal digits of precision

Floating-Point Example

- Represent -0.75
 - $-0.75 = (-1)^1 \times 1.1_2 \times 2^{-1}$
 - $S = 1$
 - Fraction = $1000\dots00_2$
 - Exponent = $-1 + \text{Bias}$
 - Single: $-1 + 127 = 126 = 01111110_2$
 - Double: $-1 + 1023 = 1022 = 01111111110_2$
- Single: $1011111101000\dots00$
- Double: $1011111111101000\dots00$

Floating-Point Example

- What number is represented by the single-precision float

11000000101000...00

- $S = 1$
 - Fraction = $01000...00_2$
 - Exponent = $10000001_2 = 129$
- $x = (-1)^1 \times (1 + 01_2) \times 2^{(129 - 127)}$
 $= (-1) \times 1.25 \times 2^2$
 $= -5.0$

Denormal Numbers

- Exponent = 000...0 \Rightarrow hidden bit is 0

$$x = (-1)^S \times (0 + \text{Fraction}) \times 2^{-\text{Bias}}$$

- Smaller than normal numbers
 - allow for gradual underflow, with diminishing precision

- Denormal with fraction = 000...0

$$x = (-1)^S \times (0 + 0) \times 2^{-\text{Bias}} = \pm 0.0$$

Two representations
of 0.0!



Infinities and NaNs

- Exponent = 111...1, Fraction = 000...0
 - \pm Infinity
 - Can be used in subsequent calculations, avoiding need for overflow check
- Exponent = 111...1, Fraction \neq 000...0
 - Not-a-Number (NaN)
 - Indicates illegal or undefined result
 - e.g., 0.0 / 0.0
 - Can be used in subsequent calculations

Floating-Point Addition

- Consider a 4-digit decimal example
 - $9.999 \times 10^1 + 1.610 \times 10^{-1}$
- 1. Align decimal points
 - Shift number with smaller exponent
 - $9.999 \times 10^1 + 0.016 \times 10^1$
- 2. Add significands
 - $9.999 \times 10^1 + 0.016 \times 10^1 = 10.015 \times 10^1$
- 3. Normalize result & check for over/underflow
 - 1.0015×10^2
- 4. Round and renormalize if necessary
 - 1.002×10^2

Floating-Point Addition

- Now consider a 4-digit binary example
 - $1.000_2 \times 2^{-1} + -1.110_2 \times 2^{-2}$ ($0.5 + -0.4375$)
- 1. Align binary points
 - Shift number with smaller exponent
 - $1.000_2 \times 2^{-1} + -0.111_2 \times 2^{-1}$
- 2. Add significands
 - $1.000_2 \times 2^{-1} + -0.111_2 \times 2^{-1} = 0.001_2 \times 2^{-1}$
- 3. Normalize result & check for over/underflow
 - $1.000_2 \times 2^{-4}$, with no over/underflow
- 4. Round and renormalize if necessary
 - $1.000_2 \times 2^{-4}$ (no change) = 0.0625

FP Adder Hardware

- Much more complex than integer adder
- Doing it in one clock cycle would take too long
 - Much longer than integer operations
 - Slower clock would penalize all instructions
- FP adder usually takes several cycles
 - Can be pipelined

FP Adder Hardware

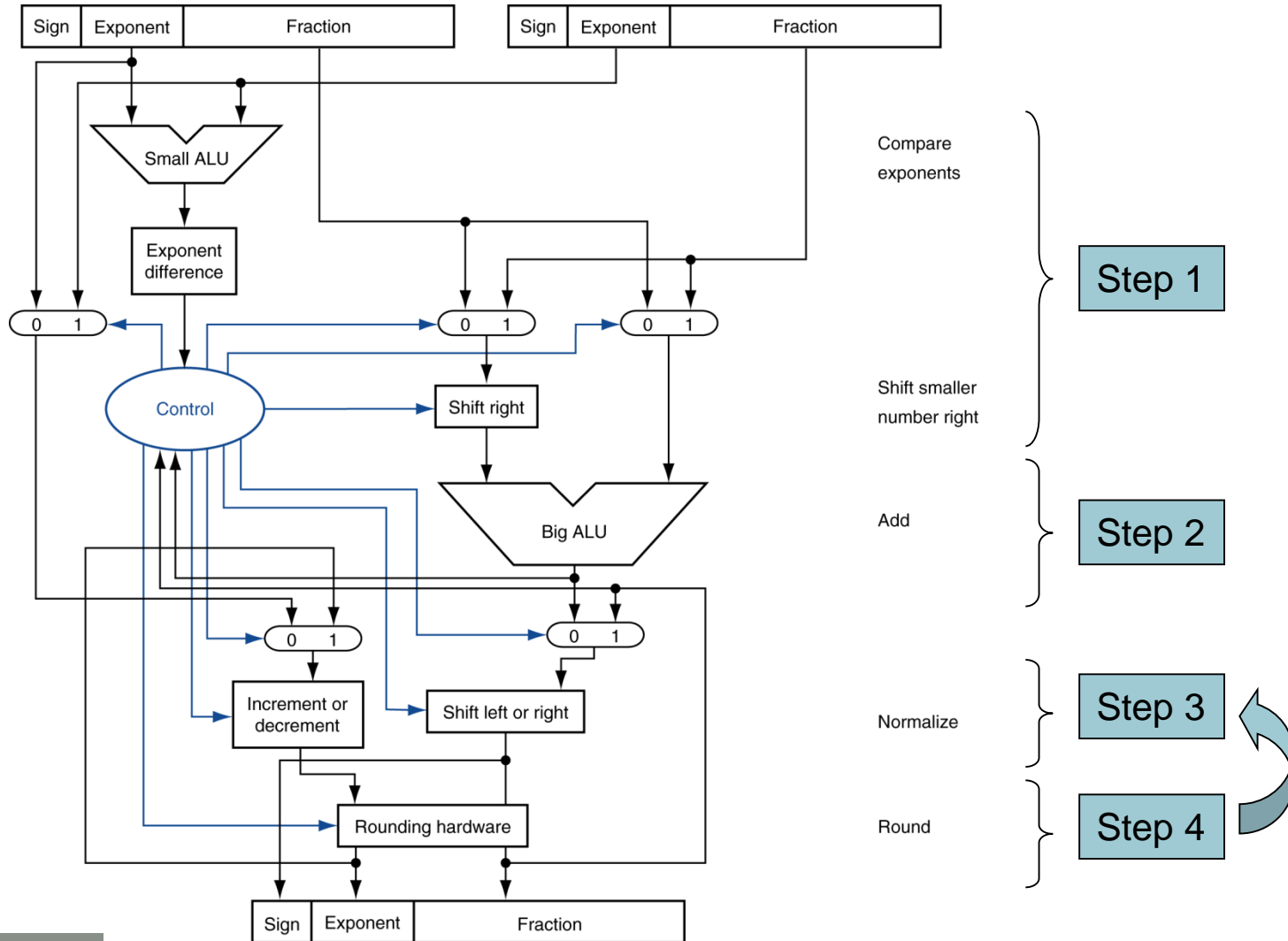

Floating-Point Multiplication

- Consider a 4-digit decimal example
 - $1.110 \times 10^{10} \times 9.200 \times 10^{-5}$
- 1. Add exponents
 - For biased exponents, subtract bias from sum
 - New exponent = $10 + -5 = 5$
- 2. Multiply significands
 - $1.110 \times 9.200 = 10.212 \Rightarrow 10.212 \times 10^5$
- 3. Normalize result & check for over/underflow
 - 1.0212×10^6
- 4. Round and renormalize if necessary
 - 1.021×10^6
- 5. Determine sign of result from signs of operands
 - $+1.021 \times 10^6$

Floating-Point Multiplication

- Now consider a 4-digit binary example
 - $1.000_2 \times 2^{-1} \times -1.110_2 \times 2^{-2}$ (0.5×-0.4375)
- 1. Add exponents
 - Unbiased: $-1 + -2 = -3$
 - Biased: $(-1 + 127) + (-2 + 127) = -3 + 254 - 127 = -3 + 127$
- 2. Multiply significands
 - $1.000_2 \times 1.110_2 = 1.110_2 \Rightarrow 1.110_2 \times 2^{-3}$
- 3. Normalize result & check for over/underflow
 - $1.110_2 \times 2^{-3}$ (no change) with no over/underflow
- 4. Round and renormalize if necessary
 - $1.110_2 \times 2^{-3}$ (no change)
- 5. Determine sign: $+ve \times -ve \Rightarrow -ve$
 - $-1.110_2 \times 2^{-3} = -0.21875$

FP Arithmetic Hardware

- FP multiplier is of similar complexity to FP adder
 - But uses a multiplier for significands instead of an adder
- FP arithmetic hardware usually does
 - Addition, subtraction, multiplication, division, reciprocal, square-root
 - FP \leftrightarrow integer conversion
- Operations usually takes several cycles
 - Can be pipelined

FP Instructions in LEGv8

- Separate FP registers
 - 32 single-precision: S0, ..., S31
 - 32 double-precision: DS0, ..., D31
 - S_n stored in the lower 32 bits of D_n
- FP instructions operate only on FP registers
 - Programs generally don't do integer ops on FP data, or vice versa
 - More registers with minimal code-size impact
- FP load and store instructions
 - LDURS, LDURD
 - STURS, STURD

FP Instructions in LEGv8

- Single-precision arithmetic
 - FADDS, FSUBS, FMULS, FDIVS
 - e.g., FADDS S2, S4, S6
- Double-precision arithmetic
 - FADDD, FSUBD, FMULD, FDIVD
 - e.g., FADDD D2, D4, D6
- Single- and double-precision comparison
 - FCMPS, FCMPD
 - Sets or clears FP condition-code bits
- Branch on FP condition code true or false
 - B.cond

FP Example: °F to °C

- C code:

```
float f2c (float fahr) {  
    return ((5.0/9.0)*(fahr - 32.0));  
}
```

- fahr in S12, result in S0, literals in global memory space

- Compiled LEGv8 code:

f2c:

```
LDURS S16, [X27, const5]    // S16 = 5.0 (5.0 in memory)  
LDURS S18, [X27, const9]    // S18 = 9.0 (9.0 in memory)  
FDIVS S16, S16, S18         // S16 = 5.0 / 9.0  
LDURS S18, [X27, const32]   // S18 = 32.0  
FSUBS S18, S12, S18         // S18 = fahr - 32.0  
FMULS S0, S16, S18         // S0 = (5/9)*(fahr - 32.0)  
BR LR                       // return
```

FP Example: Array Multiplication

- $X = X + Y \times Z$
 - All 32×32 matrices, 64-bit double-precision elements

- C code:

```
void mm (double x[][],
         double y[][], double z[][]) {
    int i, j, k;
    for (i = 0; i != 32; i = i + 1)
        for (j = 0; j != 32; j = j + 1)
            for (k = 0; k != 32; k = k + 1)
                x[i][j] = x[i][j]
                    + y[i][k] * z[k][j];
}
```

- Addresses of x, y, z in X0, X1, X2, and i, j, k in X19, X20, X21

FP Example: Array Multiplication

- LEGv8 code:

mm: . . .

```
        LDI X10, 32           // x10 = 32 (row size/loop end)
        LDI X19, 0           // i = 0; initialize 1st for loop
L1: LDI X20, 0               // j = 0; restart 2nd for loop
L2: LDI X21, 0               // k = 0; restart 3rd for loop
        LSL X11, X19, 5      // x11 = i * 2 5 (size of row of c)
        ADD X11, X11, X20    // x11 = i * size(row) + j
        LSL X11, X11, 3      // x11 = byte offset of [i][j]
        ADD X11, X0, X11     // x11 = byte address of c[i][j]
        LDURD D4, [X11,#0]   // D4 = 8 bytes of c[i][j]
L3: LSL X9, X21, 5           // x9 = k * 2 5 (size of row of b)
        ADD X9, X9, X20      // x9 = k * size(row) + j
        LSL X9, X9, 3        // x9 = byte offset of [k][j]
        ADD X9, X2, X9       // x9 = byte address of b[k][j]
        LDURD D16, [X9,#0]   // D16 = 8 bytes of b[k][j]
        LSL X9, X19, 5       // x9 = i * 2 5 (size of row of a)
```

FP Example: Array Multiplication

```
...
ADD X9, X9, X21           // X9 = i * size(row) + k
LSL X9, X9, 3             // X9 = byte offset of [i][k]
ADD X9, X1, X9            // X9 = byte address of a[i][k]
LDURD D18, [X9,#0]       // D18 = 8 bytes of a[i][k]
FMULD D16, D18, D16      // D16 = a[i][k] * b[k][j]
FADDD D4, D4, D16        // f4 = c[i][j] + a[i][k] * b[k][j]
ADDI X21, X21, 1         // $k = k + 1
CMP X21, X10             // test k vs. 32
B.LT L3                  // if (k < 32) go to L3
STURD D4, [X11,0]        // = D4
ADDI X20, X20, #1        // $j = j + 1
CMP X20, X10             // test j vs. 32
B.LT L2                  // if (j < 32) go to L2
ADDI X19, X19, #1        // $i = i + 1
CMP X19, X10             // test i vs. 32
B.LT L1                  // if (i < 32) go to L1
```

Accurate Arithmetic

- IEEE Std 754 specifies additional rounding control
 - Extra bits of precision (guard, round, sticky)
 - Choice of rounding modes
 - Allows programmer to fine-tune numerical behavior of a computation
- Not all FP units implement all options
 - Most programming languages and FP libraries just use defaults
- Trade-off between hardware complexity, performance, and market requirements

Subword Parallelism

- Graphics and audio applications can take advantage of performing simultaneous operations on short vectors
 - Example: 128-bit adder:
 - Sixteen 8-bit adds
 - Eight 16-bit adds
 - Four 32-bit adds
- Also called data-level parallelism, vector parallelism, or Single Instruction, Multiple Data (SIMD)

ARMv8 SIMD

- 32 128-bit registers (V0, ..., V31)
- Works with integer and FP
- Examples:
 - 16 8-bit integer adds:
 - `ADD V1.16B, V2.16B, V3.16B`
 - 4 32-bit FP adds:
 - `FADD V1.4S, V2.4S, V3.4S`

Other ARMv8 Features

- 245 SIMD instructions, including:
 - Square root
 - Fused multiply-add, multiply-subtract
 - Conversion and scalar and vector round-to-integral
 - Structured (strided) vector load/stores
 - Saturating arithmetic

x86 FP Architecture

- Originally based on 8087 FP coprocessor
 - 8 × 80-bit extended-precision registers
 - Used as a push-down stack
 - Registers indexed from TOS: ST(0), ST(1), ...
- FP values are 32-bit or 64 in memory
 - Converted on load/store of memory operand
 - Integer operands can also be converted on load/store
- Very difficult to generate and optimize code
 - Result: poor FP performance

x86 FP Instructions

Data transfer	Arithmetic	Compare	Transcendental
FILD mem/ST(i)	FIADDP mem/ST(i)	FICOMP	FPATAN
FISTP mem/ST(i)	FISUBRP mem/ST(i)	FIUCOMP	F2XMI
FLDPI	FIMULP mem/ST(i)	FSTSW AX/mem	FCOS
FLD1	FIDIVRP mem/ST(i)		FPTAN
FLDZ	FSQRT		FPREM
	FABS		FPSIN
	FRNDINT		FYL2X

- Optional variations
 - I: integer operand
 - P: pop operand from stack
 - R: reverse operand order
 - But not all combinations allowed

Streaming SIMD Extension 2 (SSE2)

- Adds 4×128 -bit registers
 - Extended to 8 registers in AMD64/EM64T
- Can be used for multiple FP operands
 - 2×64 -bit double precision
 - 4×32 -bit double precision
 - Instructions operate on them simultaneously
 - Single-Instruction Multiple-Data

Matrix Multiply

■ Unoptimized code:

```
1. void dgemm (int n, double* A, double* B, double* C)
2. {
3.   for (int i = 0; i < n; ++i)
4.     for (int j = 0; j < n; ++j)
5.       {
6.         double cij = C[i+j*n]; /* cij = C[i][j] */
7.         for(int k = 0; k < n; k++ )
8.           cij += A[i+k*n] * B[k+j*n]; /* cij += A[i][k]*B[k][j] */
9.         C[i+j*n] = cij; /* C[i][j] = cij */
10.      }
11. }
```

Matrix Multiply

■ x86 assembly code:

```
1. vmovsd (%r10),%xmm0 # Load 1 element of C into %xmm0
2. mov %rsi,%rcx # register %rcx = %rsi
3. xor %eax,%eax # register %eax = 0
4. vmovsd (%rcx),%xmm1 # Load 1 element of B into %xmm1
5. add %r9,%rcx # register %rcx = %rcx + %r9
6. vmulsd (%r8,%rax,8),%xmm1,%xmm1 # Multiply %xmm1,
element of A
7. add $0x1,%rax # register %rax = %rax + 1
8. cmp %eax,%edi # compare %eax to %edi
9. vaddsd %xmm1,%xmm0,%xmm0 # Add %xmm1, %xmm0
10. jg 30 <dgemm+0x30> # jump if %eax > %edi
11. add $0x1,%r11d # register %r11 = %r11 + 1
12. vmovsd %xmm0,(%r10) # Store %xmm0 into C element
```

Matrix Multiply

■ Optimized C code:

```
1. #include <x86intrin.h>
2. void dgemm (int n, double* A, double* B, double* C)
3. {
4.     for ( int i = 0; i < n; i+=4 )
5.         for ( int j = 0; j < n; j++ ) {
6.             __m256d c0 = _mm256_load_pd(C+i+j*n); /* c0 = C[i][j] */
7.             for( int k = 0; k < n; k++ )
8.                 c0 = _mm256_add_pd(c0, /* c0 += A[i][k]*B[k][j] */
9.                                     _mm256_mul_pd(_mm256_load_pd(A+i+k*n),
10.                                                    _mm256_broadcast_sd(B+k+j*n)));
11.             _mm256_store_pd(C+i+j*n, c0); /* C[i][j] = c0 */
12.         }
13. }
```

Matrix Multiply

■ Optimized x86 assembly code:

```

1. vmovapd (%r11),%ymm0      # Load 4 elements of C into %ymm0
2. mov %rbx,%rcx             # register %rcx = %rbx
3. xor %eax,%eax             # register %eax = 0
4. vbroadcastsd (%rax,%r8,1),%ymm1 # Make 4 copies of B element
5. add $0x8,%rax             # register %rax = %rax + 8
6. vmulpd (%rcx),%ymm1,%ymm1 # Parallel mul %ymm1,4 A elements
7. add %r9,%rcx              # register %rcx = %rcx + %r9
8. cmp %r10,%rax             # compare %r10 to %rax
9. vaddpd %ymm1,%ymm0,%ymm0 # Parallel add %ymm1, %ymm0
10. jne 50 <dgemm+0x50>      # jump if not %r10 != %rax
11. add $0x1,%esi            # register % esi = % esi + 1
12. vmovapd %ymm0,(%r11)    # Store %ymm0 into 4 C elements

```

Right Shift and Division

- Left shift by i places multiplies an integer by 2^i
- Right shift divides by 2^i ?
 - Only for unsigned integers
- For signed integers
 - Arithmetic right shift: replicate the sign bit
 - e.g., $-5 / 4$
 - $11111011_2 \gg 2 = 11111110_2 = -2$
 - Rounds toward $-\infty$
 - c.f. $11111011_2 \ggg 2 = 00111110_2 = +62$

Associativity

- Parallel programs may interleave operations in unexpected orders
 - Assumptions of associativity may fail

		$(x+y)+z$	$x+(y+z)$
x	-1.50E+38		-1.50E+38
y	1.50E+38	0.00E+00	
z	1.0	1.0	1.50E+38
		1.00E+00	0.00E+00

- Need to validate parallel programs under varying degrees of parallelism

Who Cares About FP Accuracy?

- Important for scientific code
 - But for everyday consumer use?
 - “My bank balance is out by 0.0002¢!” ☹
- The Intel Pentium FDIV bug
 - The market expects accuracy
 - See Colwell, *The Pentium Chronicles*

Concluding Remarks

- Bits have no inherent meaning
 - Interpretation depends on the instructions applied
- Computer representations of numbers
 - Finite range and precision
 - Need to account for this in programs

Concluding Remarks

- ISAs support arithmetic
 - Signed and unsigned integers
 - Floating-point approximation to reals
- Bounded range and precision
 - Operations can overflow and underflow